

## AKM 115S: Rotary drive with Sauter universal technology for ball valve

### How energy efficiency is improved

Automatic adaptation to ball valve, precision control and high energy efficiency with minimal operating noise.

### Areas of application

For actuating 2-way and 3-way ball valves in the VKR and BKR series. For controllers with continuous output (0 - 10 V) or switching output (2-point or 3-point control).

### Features

- Stepping motor with SUT (Sauter Universal Technology) electronic control unit
- Automatic detection of control signal applied (continuous or switching)
- The type of characteristic curve (linear, quadratic or equal percentage) can be adjusted in the drive
- Direction of travel can be switched on cable
- Electronic, load-dependent cut-off by means of stops in drive
- Coding switch for selection of characteristic and running time (35, 60 or 120 sec.)
- Maintenance-free gearbox with magnetic clutch
- Gearbox that can be disengaged for positioning the ball valve manually (with hand lever)
- Assembly with ball valve without any tools

### Technical description

- Two-part housing made of self-extinguishing plastic, lower section black, upper section yellow
- Console and bayonet ring made of glass-fibre-reinforced plastic for fitting onto ball valve
- Connecting cable 1.2 m long, 5x 0.5 mm<sup>2</sup>
- Installation position: vertically to horizontally, but not upside down



T10644



Y07552

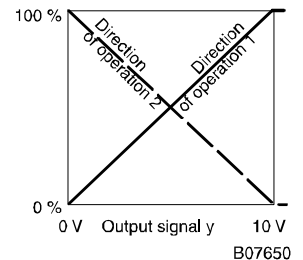

Type	Running time s	Rotation angle	Voltage	Weight kg
<b>AKM 115S F132</b>	35 / 60 / 120	90°	24 V~/=	0,7
<b>Positioner <sup>1)</sup></b>				
Control signal	0...10 V, R <sub>i</sub> > 100 kΩ	Start point U <sub>0</sub>	0 or 10 V	
Position feedback signal	0...10 V, load > 10 kΩ	Control span ΔU	10 V	
		Switching range X <sub>sh</sub>	200 mV	
Supply voltage	24V~ ± 20%, 50...60 Hz 24V= <sup>2)</sup> + 20% / - 10%	Protection class (horiz.)	IP 54 acc. to EN 60529	
		Protection class	III acc. to IEC 60730	
		Response time <sup>1)</sup>	200 ms	
Power consumption	4,9 W 8,7 VA	Connection diagram	<a href="#">A10520</a>	
		Dimension drawing	<a href="#">M10489</a>	
Max. medium temperature <sup>3)</sup>	100 °C	Fitting instructions	P100001578	
Perm. ambient temperature	-10...55 °C	Declaration on materials and the environment	MD 51.364	
Perm. ambient humidity:	5...95% rh without condensation			

### Accessories

- 0313529 001\*** Split-range unit for selecting sequences  
Installation according to MV 505671 in separate distribution socket
- 0372462 001** CASE Drives PC Tool for configuring drives using computer; MV 506101
- 0510420 001\*** Temperature adapter required at >100 °C medium temperature (recommended at a temperature of <10 °C); P100002660
- 0510480 001\*** Auxiliary change-over switch <sup>4)</sup> single; P100002035
- 0510480 002\*** Auxiliary change-over switch <sup>4)</sup> double; P100002035

\*) Dimension drawing or connection diagram available under same number

- 1) Also for 2-point or 3-point, depending on connection type
- 2) 24V= for all functions
- 3) For medium temperature > 100 °C use appropriate accessory
- 4) Infinitely adjustable 0...100%, perm. load 5(2) A, 24 to 230 V

**Function**

Depending on the type of connection (see connecting plan) the drive can be used as a continuous 0...10 V drive or a 2-point (open/closed) or 3-point (open/stop/closed) drive with intermediate position. The running time of the drive can be set in accordance with requirements using coding switches. The equal-percentage, linear or quadratic characteristic curve can be selected using the coding switches. The AKM 115 is combined with ball valves with an equal percentage basic characteristic curve like the VKR or BKR.

Manual adjustment takes place by disengaging the gearbox (slide switch next to connecting cable) and simultaneous rotation using the manual adjusting lever. The drive position is indicated by the manual adjusting lever or the indicator knob on the upper part of the drive.

Attention: return slide switch after making manual adjustment (engage gearbox).

**Connection as 2-point valve drive**

This open/closed actuation can take place via 2 cables. The drive is connected to the voltage via the blue and brown cables. The control branch of the ball valve is opened by applying voltage to the black cable. When this voltage is switched off, the drive moves to the opposite end position and closes the ball valve.

The unused red and grey lines must not be connected or come into contact with other cables. We recommend that these cables be isolated.

**Connection as 3-point actuator**

The ball valve can be moved to any position by applying voltage to the brown or black cable. Direction of rotation (viewed from drive to ball valve spindle):

- - axle rotates clockwise with voltage applied to brown cable, closes the ball valve.
- - axle rotates anticlockwise with voltage applied to black cable.

In the end positions (stop in drive, maximum rotation angle of 95 ° reached) or in the event of overloading the electric motor shut-off mechanism is activated (not a limit switch). The rotating angle can be changed by swapping the cables.

The unused red and grey lines must not be connected or come into contact with other cables. We recommend that these cables be isolated.

**Connection for 0...10 V control voltage**

The built-in positioner controls the drive depending on the controller output signal  $y$ .

Direction of rotation (viewed from drive to ball valve spindle):

Mode of action 1 (mains voltage applied to brown cable):

As the output signal increases, the driver axle rotates anticlockwise and opens the control passage of the ball valve.

Mode of action 2 (mains voltage applied to black cable):

As the output signal increases, the driver axle rotates clockwise and closes the control passage of the ball valve.

The start point and the control span are fixed.

Voltage must only be applied to either the brown cable or the black cable. The cable that is not used must be isolated (if not connected to a switch).

Since the start point and the control span are fixed, a split range unit is needed to adjust partial ranges (accessory).









After manual adjustments or if the voltage has been interrupted for more than 5 minutes the drive recalibrates itself, with a running time of 60 s in all cases.

When the supply voltage is applied the stepping motor moves to the 100% position, makes the connection to the driver axle, moves to the 0% position and therefore defines the operating range. It is then possible to move to any position between a rotation angle of 0 und 90 °, depending on the control voltage. Thanks to the electronics no steps are lost, and the drive does not require occasional recalibration. The parallel running of several drives of this type is guaranteed. The positional feedback  $y_0 = 0...10$  V corresponds to the effective rotation angle of 0 to 90 °.

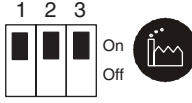
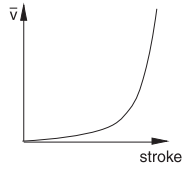
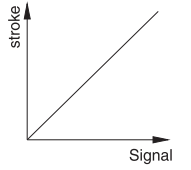
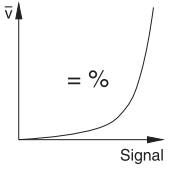
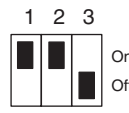
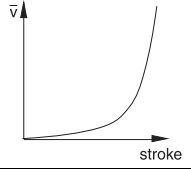
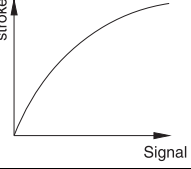
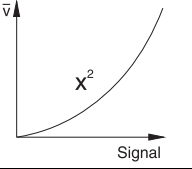
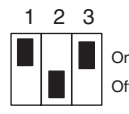
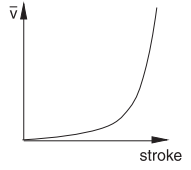
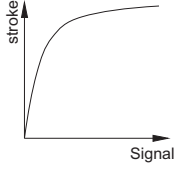
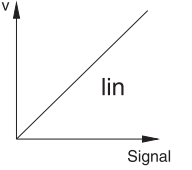
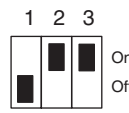
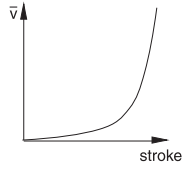
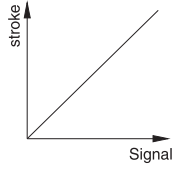
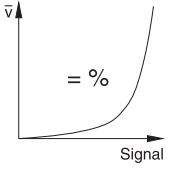
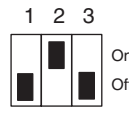
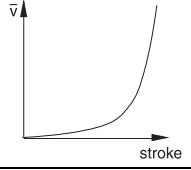
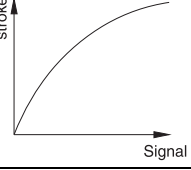
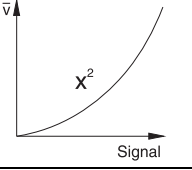
If the 0...10 V control signal is interrupted and mode of action 1 is connected, the ball valve is fully closed (0% position).

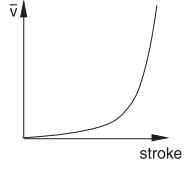
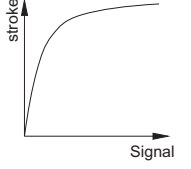
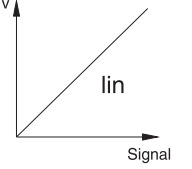
The characteristic curve of the ball valve can be selected using the coding switch. Characteristic curves can only be generated if the drive is used as a continuous drive. The running times can be selected using other switches. These can be used regardless of whether the 2-point, 3-point or continuous function has been selected.

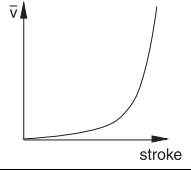
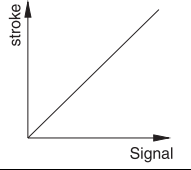
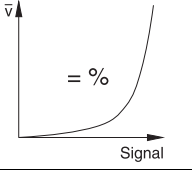
**Coding switches for running time and characteristic curve selection**

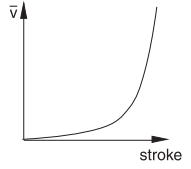
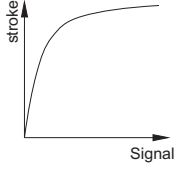
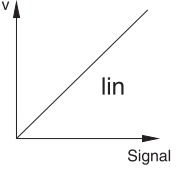
Position of switches				Running time/angle s/90°
				120 s ± 4
				120 s ± 4
				120 s ± 4
				60 s ± 2
				60 s ± 2
				60 s ± 2
				35 s ± 1
				35 s ± 1

**Split range unit, accessory 0361529 001**

The start point  $U_0$  and the control span  $\Delta U$  can be adjusted using potentiometers. This allows several actuators to be operated in sequence or cascade using the controller's control signal. The input signal (partial range) is amplified into a 0...10 V output signal. This accessory cannot be installed in the drive but must be accommodated externally in an electric distribution socket.

**CASE Drives PC Tool, accessory 0372462 001**

The drive parameters can be set and read out on site using CASE Drives. The connection is made via a serial interface on the PC (Laptop) or via the socket contact on the drive. The set consists of: software including installation and operating instructions, installation guide, connector, connecting cable (1,2 m long) Intended for use by commissioning and service engineers and experienced operators.

The final setting, be it with coding switches or CASE drives, has top priority. If a change is made at the coding switch, this setting is active. In order to prevent the settings made with CASE Drives from being overwritten, the coding switch can be removed using tweezers (special tool, included in scope of delivery).

**Engineering and fitting notes**

Condensation, drip water etc. must be prevented from penetrating the drive along the carrier axle.

When the electrical connection is being made, it must be ensured that the cross-section of the supply line is adapted to the output and the length. However, we recommend a minimum cross-section of 0,75 mm<sup>2</sup>.

The drive / ball valve are installed by fitting them and rotating the bayonet ring as far as it will go without any further adjustment. No tools are needed. The spindle of the ball valve is connected to the driver axle automatically, either by moving to a rotation angle of 100% using manual adjustment or by applying the voltage. Dismantling takes place by simply opening the bayonet ring and removing the drive. The delivery setting is the centre position.

The stepping motor and electronic system ensure that several valve drives of the same SUT type will run in parallel.

If a potentiometer is needed, the accessories of AVM 105, 115 can be used but display (% rotation angle) on the name plate will be inverted. The maximum accessory configuration that can be used for a drive is 1 auxiliary change-over switch or 1 potentiometer.

The auxiliary change-over switch accessory is screwed to the top cover of the drive. The indicator knob must be removed to make the mechanical connection. A new indicator can be seen on the cover of the accessory.

The coding switches are accessible via a prepared opening with a black cover in the top of the housing.

Attention! The housing must not be opened.

**Fitting outdoors.** We recommend that the equipment is provided with additional protection from the weather if it is installed outside.

**Additional technical tasks**

The upper housing with cover, indicator knob and cover knob contains the stepping motor and the SUT electronics. The lower part of the housing contains the maintenance-free gearbox.

**Auxiliary change-over switch**

Switching capacity max. 230 V~, current min. 20 mA at 20 V

Switching capacity max. 4...30 V=, current 1...100 mA

**Power consumption:**

Type	Running time s	Condition	active power P W	apparent power S VA
AKM 115S F132	35	Operation	2,45	4,75
		Stationary	0,35	0,8
	60	Operation	4,9	8,7
		Stationary	0,35	0,75
	120	Operation	2,25	4,3
		Stationary	0,35	0,75

**CE conformity**

EMC directive 2004/108/EC

EN 61000-6-1

EN 61000-6-3

EN 61000-6-4

Machinery directive 98/37/EEC (II B)

EN 1050

Connection diagram

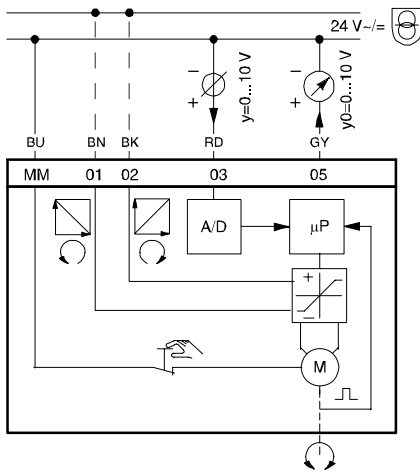

Variante 1 (3pt)

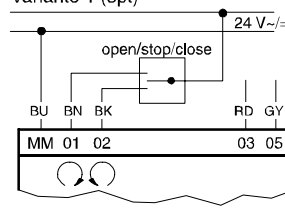

Variante 2 (2pt)

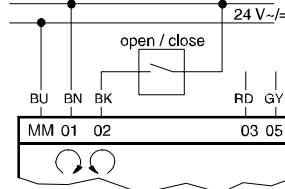

RD = red  
 BN = brown  
 BK = black  
 BU = blue  
 GY = grey

A10520a

Dimension drawing

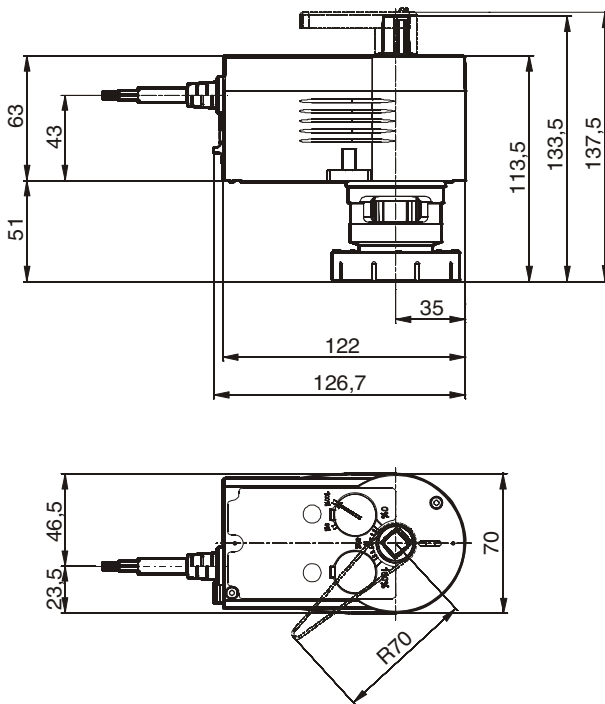

M10489

**Accessories**

0510480 001

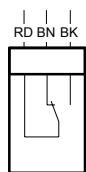

A09782

RD = red  
 BN = brown  
 BK = black  
 GN = green  
 GY = grey  
 VT = violet

0510480 002

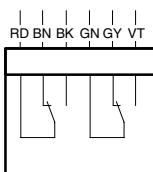

A10183

0313529

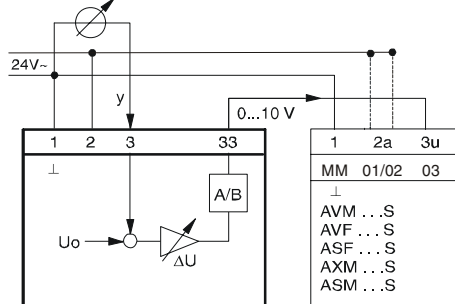

A09421c

0510420 001

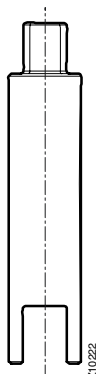
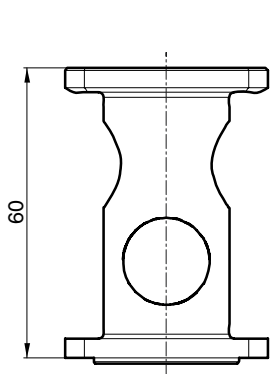

Z10/022