

## ASF 112, 113: Actuators with spring return

### How energy efficiency is improved

Overload protection and end stop detection for efficient energy use.

### Areas of application

For controllers with a switching output (2-point or 3-point control). For actuation of air, shut-off and restrictor dampers and louvres.

### Features

- 7 Nm torque and holding torque
- 230 V, 50/60 Hz or 24 V~/=
- 90 sec. running time for 90°
- Protection class IP54, vertical
- Self-centring axle adaptor
- Manual adjustment with hexagon socket, including locking gears
- Non-wearing, brushless motor
- Maintenance-free

### Technical description

- Robust all-metal housing
- Suitable for all installation positions
- Connecting cable 0.9 m long, 0.75 mm<sup>2</sup>
- Change direction of rotation simply by turning the drive



T110002



Y01994

Type	Running time for 90° in sec		Control	Power	Weight kg
	Motor	Spring return			
<b>ASF 112 F120</b>	90	15	2-point	230 V~	1,2
<b>ASF 112 F122</b>	90	15	2-point	24 V~ / 24...48 V=	1,2
<b>ASF 113 F122</b>	90	15	3-point	24 V~ / 24...48 V=	1,2
With double auxiliary contacts <sup>1)</sup> 6 (2) A; 24...250 V~ with cable of 0,9 m; 6 x 0,75 mm <sup>2</sup>					
<b>ASF 112 F220</b>	90	15	2-point	230 V~	1,3
<b>ASF 112 F222</b>	90	15	2-point	24 V~ / 24...48 V=	1,3
Power supply	230 V~	± 10%, 50...60 Hz	Degree of protection		IP 42 as per EN 60529
	24 V~	± 20%, 50...60 Hz	see fitting instructions <sup>2)</sup>		IP 54
	24...48 V=	± 20%			
Power consumption			Protection class	230 V	II as per IEC 60730
ASF 112 F120	2,6 W	4,6 VA		24 V	III as per IEC 60730
ASF 112 F122	2,0 W	3,0 VA			
Torque and holding torque	7 Nm		Wiring diagram	2 pt	<a href="#">A05769</a>
Angle of rotation	max. 95°			3 pt	<a href="#">A05770</a>
Permissible damper area <sup>3)</sup>	ca. 1,5 m <sup>2</sup>				
Permissible ambient temp.	-32...55 °C		Dimension drawing	<a href="#">M09970</a>	
Permissible ambient humidity	5...95 %rh		Fitting instructions	<a href="#">MV 505820</a>	

### Accessories

- 0372245 001** Lever adaptor for changing the rotary movement into stroke; MV 505824
- 0372245 002** Lever adaptor for changing the rotary movement into stroke; with plate for fixing to wall or plinth; MV 505825
- 0510240 001** Mounting kit for ball valves VKR/BKR for damper drives ASF 112 and 113 from index B, MV P100002479

1) Switching range 5°...85° (factory setting), variable in steps of 5°, switching difference 2°

2) Degree of protection IP 54, see positional information on MV 505820

3) Recommended value for easy-acting air damper

## Operation

### Two-point version

After the power supply has been connected, the final control element is moved towards the 90° position until the load-dependent cut-off operates (scale on drive; max. angle of rotation 95°). The gears (with the brushless d.c. motor) is stopped and blocked. In the event of a power failure, or when the power is switched off, the motor releases the gears, and the coupling piece is turned back by the spring to the 0° position.

### Three-point version

The drive turns from 0° to 90° when power is applied to terminal 2 (purple wire), and from 90° to 0° when applied to terminal 3 (orange wire). In the mid-position of the 3-point controller, the drive stops. In the event of a power failure, or when the power is switched off by a safety device at terminal 21 (red wire), the motor releases the gears, and the coupling piece is turned back by the spring to the 0° position.

In the two end positions (on reaching either the damper stop, the stop of the angle limiter or the maximum angle of 95°), or in the event of an overload, the torque-dependent cut-out comes into operation (no limit switches).

### Engineering and fitting notes

The use of electronics allows several dampers with different torques to be run in parallel. It is essential that the operating voltage lies within the prescribed tolerances. The actuator can be mounted in any position, can be inserted directly onto the damper shaft and is fixed using the self-centring clamp.

The subsequent fitting of auxiliary switches or potentiometers is not possible.

The angle of rotation can, between 0° and 90°, be limited in steps of 5°.

N.B.: The housing must not be opened, since the return spring may cause injury.

**Fitting outdoors.** If the devices are fitted outdoors, we recommend that additional measures be taken to protect them against the effects of the weather.

### Additional technical data

The two-part housing (which must not be opened) contains: the brushless d.c. motor; the electronic control unit; the maintenance-free, non-jamming gears; the return spring; and (on the 230 V model) the transformer. The direction of operation can be changed by fitting the actuator onto the damper spindle the other way round (changing the rotary direction of the safety function). The coupling piece is suitable for damper spindles of Ø 6,4...20,5 mm, □6,4...13 mm.

Using the Allen key supplied, the drive can be turned to, and locked in, any position (see MV 505820). The gears are freed again either by unlocking them mechanically or by applying the operating power.

### Power consumption:

Type	Running time s	Condition	active power P W	apparent power S VA
ASF 112 F120	90	Operating	2,6	4,6
		Standstill	0,26	0,48
ASF 112 F122	90	Operating	2,0	3,0
		Standstill	1,9	2,9

### CE conformity

EMC directive 2004/108/EC	Machine directive 98/37/EEC (II B)	Low-voltage directive 73/23/EEC
EN 61000-6-2	EN 1050	EN 60730-1
EN 61000-6-3		EN 60730-2-14
		Over-voltage category III
		Degree of pollution II

**Wiring diagrams**

ASF 112 (2 pt)

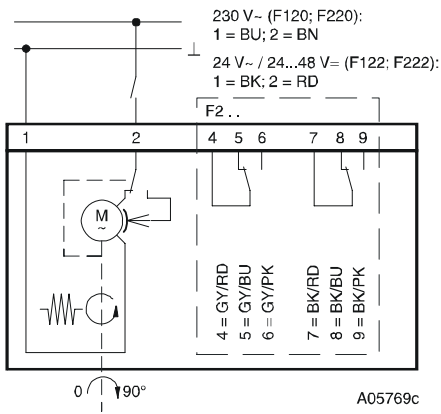

ASF 113 (3 pt)

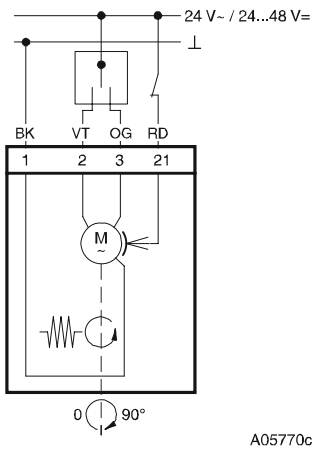

**Dimension drawing**

