

## AVM 105, 115: Actuators

### How energy efficiency is improved

Torque-dependent cut-off for efficient energy use.

### Areas of application

Actuation of through and three-way valves in the VUN/BUN, VUD/BUD and VUE/BUE, DN15 to DN50 series. For controllers with a switching output (2/3-point control).

### Features

- Pushing force 250 N in the case of the AVM 105 and 500 N in the case of the AVM 115
- Synchronous motor with control and electronic cut-off
- Electronic end position detection and motor cut-off with time switch in the device
- Maintenance-free gearbox with magnetic clutch
- Gearbox that can be disengaged for positioning valve manually (Allen key included)
- Assembly with valve takes place more or less automatically

### Technical description

- Two-part housing made of self-extinguishing plastic, lower section black, upper section yellow
- Console made of glass-fibre-reinforced plastic
- Brass box nut for fitting valve
- Connecting cable 1.2 m long, 3x 0.75 mm<sup>2</sup>
- Depending on the model, the running time for 8 mm stroke is 30 or 120 secs
- Installation position: vertical to horizontal, but not upside down



T10873



Y07551

Type	Control	Running time s	Stroke mm	Pushing force N	Power	Weight kg
<b>AVM 105 F100</b>	2/3-point	30	8	250	230 V~	0,7
<b>AVM 105 F120</b>	2/3-point	120	8	250	230 V~	0,7
<b>AVM 105 F122</b>	2/3-point	120	8	250	24 V~	0,7
<b>AVM 115 F120</b>	2/3-point	120	8	500	230 V~	0,7
<b>AVM 115 F122</b>	2/3-point	120	8	500	24 V~	0,7
Power supply	230 V~ ± 15%, 50...60 Hz 24 V~ ± 20%, 50...60 Hz			Protection (horizontal) Protection class	24 V 230 V	IP 54 as per EN 60529 III as per IEC 60730 II as per IEC 60730
Power consumption				Min. response time		200 ms
F100	2,4 W	4,5 VA		Wiring diagram	2-point	<a href="#">A10351</a>
F120	2,0 W	4,0 VA			3-point	<a href="#">A09679</a>
F122	1,6 W	1,7 VA		Dimension drawing		<a href="#">M09743</a>
Max. media temperature	100 °C			Fitting instructions		MV 505790
Permissible ambient temp.	-10...55°C			Declaration on materials		MD 51.361
Ambient humidity	5...95 %rh without condensation					

For control valve type KTM512 / TA-Regulator DN 15...50

Type	Control	Running time [s]	Stroke [mm]	Pushing force [N]	Power	Weight [kg]
<b>AVM 115 F901</b>	2/3-point	160	10	500	230 V~	0,7

Deviation from standard type: inverse scale therefore inverse connection. Adaptor for control valve available on the valve, or from TA-Regulator, stating reference no. 52 757 003.

### Accessories

- 0372145 001\*** Single auxiliary change-over contacts <sup>1)</sup>; MV 505795
- 0372145 002\*** Double auxiliary change-over contacts <sup>1)</sup>; MV 505795
- 0372249 001\*** Intermediate piece required for media temperature >100 °C for BXN / VXN (recommended for temperature < 10 °C); MV 505932
- 0372273 001\*** Adaptor for Siemens VVG / VXG 44 and 48 valves; MV 505848
- 0372286 001** Potentiometer <sup>2)</sup> 130 Ω; MV 505795
- 0372286 002** Potentiometer <sup>2)</sup> 1000 Ω; MV 505795
- 0372286 003** Potentiometer <sup>2)</sup> 5000 Ω; MV 505795
- 0372320 001** Allen key for manual adjustment
- 0372459 100\*** External circuitry 230V version for parallel operation with ASM/AVM 104, 114 or actuators with end-switch, incl. distribution box; MV 506102
- 0372459 102\*** External circuitry 24V version for parallel operation with ASM/AVM 104, 114 or actuators with end-switch, incl. distribution box; MV 506102

<sup>\*)</sup> Dimension drawing or wiring diagram are available under the same number

1) Infinitely variable from 0...100%; max. load 5(2) A, 24...230 V

2) Only one potentiometer or one set of auxiliary contacts can be fitted to each drive!

### Operation

By applying power to the cable, the final control element can be moved to any position by means of the coupling rod.

Direction of stroke movement in the case of 3-point control:-

- The coupling rod extends (and the valve opens) if power is applied to the drive via the blue (MM/N) and the brown (01) wires.
- The coupling rod retracts (and the valve closes) if power is applied to the drive via the blue (MM/N) and the black (02) wires.

In the case of 3-point control, the direction can be changed by transposing the connections.

Direction of stroke movement in the case of 2-point control (the black wire 02 is always live):-

- The coupling rod extends (and the valve opens) if power is applied to the drive via the blue (MM/N) and the brown (01) wires.
- The coupling rod retracts (and the valve closes) if power is applied to the drive via the blue (MM/N) wire, and power is not applied to the brown (01) wire.

In both end positions (i.e. on hitting a stop in the valve or reaching the maximum stroke), or in the event of an overload, the magnetic coupling is activated. The control signal is switched off by the electronic cut-out after three minutes (60 seconds for F100).

Manual adjustment is performed by disengaging the gears (sliding switch next to the power cable) and simultaneously turning, using an Allen key in the insert on the upper part of the drive. Eight mm of stroke is attained with 1½ turns.

N.B.: After manual adjustment, re-set the sliding switch (engage the gears).

### Engineering and fitting notes

The ingress of condensate, drops of water etc. along the valve spindle and into the drive should be prevented. Should not be fitted upside down.

The assembly of drive and valve is done by fitting and tightening the cap nut without further adjustment; no tools should be used. The valve spindle and the drive spindle are coupled together automatically, either by using the manual adjustment facility and moving to 100% stroke, or by applying power at terminals MM/N and 01. To disassemble, the drive and valve spindles should be loosened first, then the cap nut.

The drive is supplied ex works in the middle position.

The concept of a synchronous motor combined with a magnetic coupling ensures parallel operation of more than one valve drive of the same type.

The following accessories can be fitted to each actuator: either one set of auxiliary contacts or a potentiometer.

The auxiliary contacts should be screwed onto the drive's top cover. Before the mechanical connection can be established, the indicator knob should be removed. A new indicator is then visible on the lid of the auxiliary contacts.

N.B.: The housing should not be opened.

**Fitting outdoors.** If the devices are fitted outdoors, we recommend that additional measures be taken to protect them against the effects of the weather.

### Additional technical data

The upper part of the housing, with the lid and indicator knob, contains the synchronous motor with the capacitor. The lower part contains the maintenance-free gears and the gear-release knob.

Auxiliary change-over contacts

Switch rating: max. 230 V a.c.; min. current 20 mA at 20 V

Switch rating: max. 4...30 V d.c.; current 1...100 mA

Power consumption:

Type	Running time s	Condition	active power P W	apparent power S VA
AVM 105 F100	30	Operating	2,4	4,5
AVM 105 F120	120	Operating	2,0	4,0
AVM 105 F122	120	Operating	1,6	1,7
AVM 115 F120	120	Operating	2,0	4,0
AVM 115 F122	120	Operating	1,6	1,7

### CE conformity

EMC directive 2004/108/EC	Machine directive 98/37/EEC (II B)	Low-voltage directive 2006/95/EC
EN 61000-6-1	EN 1050	EN 60730-1
EN 61000-6-2		EN 60730-2-14
EN 61000-6-3		Over-voltage category III
EN 61000-6-4		Degree of pollution II

**Wiring diagram**

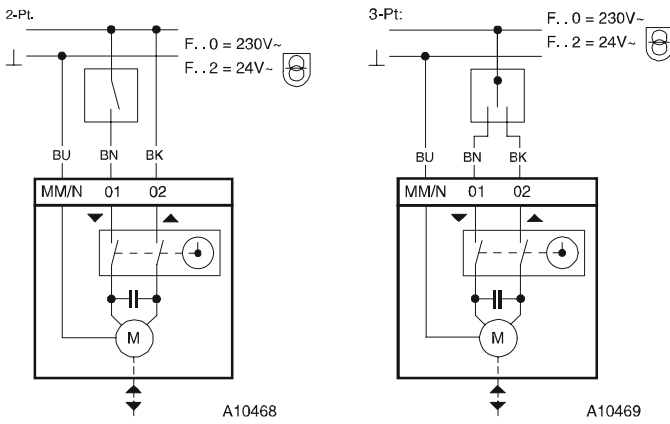

**Dimension drawing**

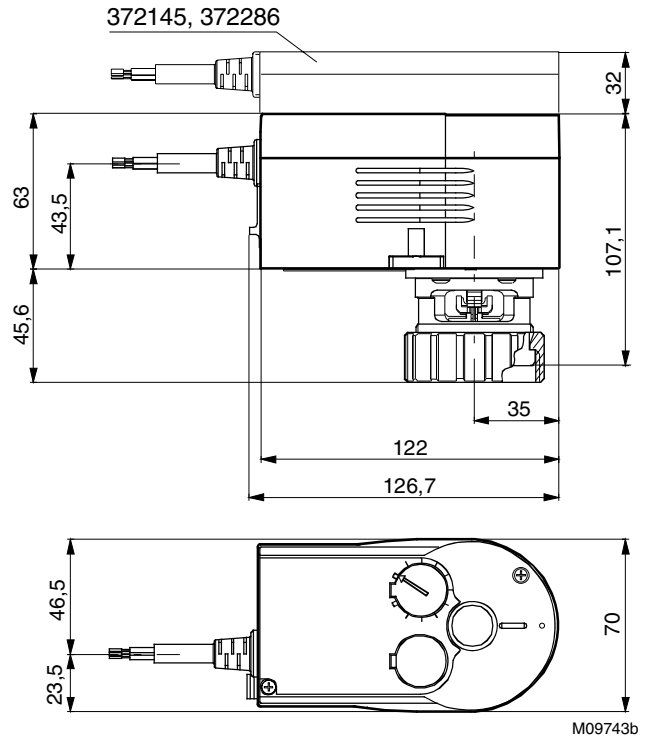

**Accessories**

372145 001

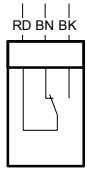

RD = red  
BN = brown  
BK = black  
BU = blue  
GY = grey

372145 002

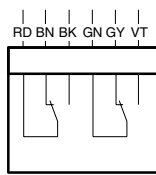

372459 10 .

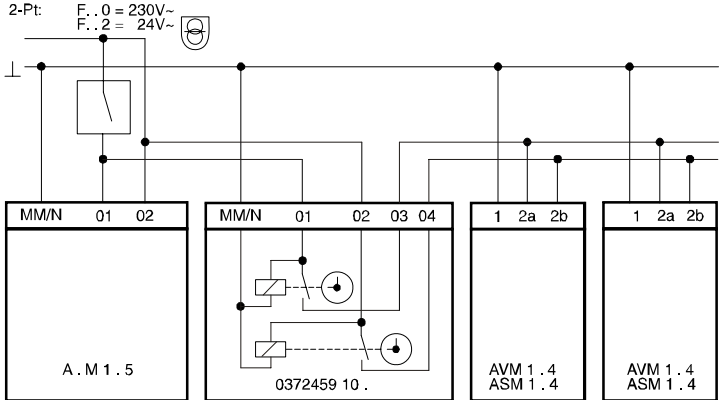

0372249 001

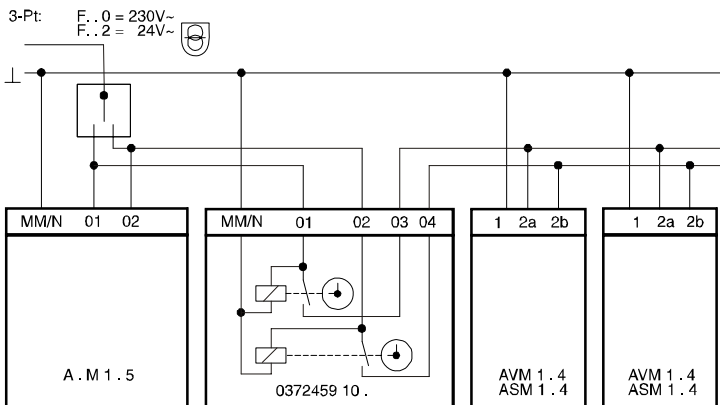
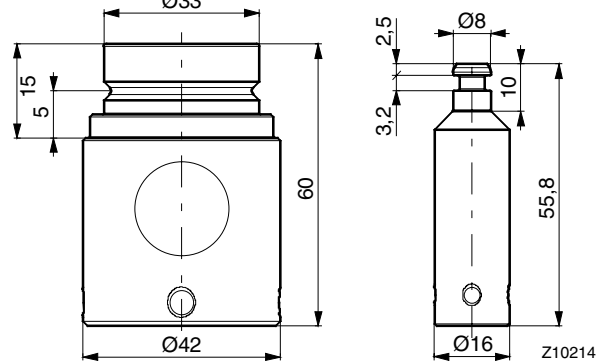

372273

