

DEF: Wafer butterfly valve, tightly-closing, PN 16

How energy efficiency is improved

Intelligent collar design for working without losses through leakage.

Areas of application

Continuous control of water, air and low-pressure steam up to 110°C, or for use as a shut-off valve.

Features

- Nominal pressure 16 bar
- Butterfly valve with 3-way brass bearing bush as spindle bearing
- Fits PN6, PN10 and PN16 flanges
- Nominal diameters DN25 to DN200
- K_{VS} values of 36 m³/h to 4000 m³/h available
- Suitable drives include motor drives of the AR30W and A44W type or ASF 122 and 123 damper drives with a spring return action

Technical description

- Damper body made of cast iron
- Collar made of ethylene-propylene rubber
- Butterfly wafer made of stainless steel
- Spindle in stainless steel sealed with two O-rings
- Linear characteristic



T04237



Y07548

Type	Nominal width DN	K _{VS} value m³/h	Weight kg
DEF 025 F200	25	36	1.00
DEF 032 F200	32	40	1.15
DEF 040 F200	40	50	2.75
DEF 050 F200	50	85	3.05
DEF 065 F200	65	215	4.05
DEF 080 F200	80	420	4.30
DEF 100 F200	100	800	4.85
DEF 125 F200	125	1010	7.20
DEF 150 F200	150	2100	9.50
DEF 200 F200	200	4000	12.00

Nominal pressure	PN 16	Dimension drawings	5M109
Max. perm. operating pressure	16 bar		
Control characteristic	linear	Fitting instructions	MV 505826
Angle of butterfly rotation	90°	Assembly ASF	MV 505833
Leakage rate	< 0.0001% of k _{VS} 1)	Assembly AR30	MV 505831
Permissible operating temperature	-10...130 °C	Assembly A44	MV 505832

Accessories

0361632 . . . 2 counter flanges compl. PN 6 acc. to EN 1092-1
DN 25 32 40 50 65 80 100 125 150 200

0361633 . . . 2 counter flanges compl. PN 10 (DN 25...150) acc. to EN 1092-1
VSM 18717 (DIN 2632) and PN 16 (DN 25...200) acc. to EN 1092-1
DN 25 32 40 50 65 80 100 125 150 200

Specify when ordering: DN 25 = /025, DN 100 = /100

0361634 200 2 counter flanges compl. PN 10 (DN 200) acc. to EN 1092-1
0378108 001 Assembly kit; DEF DN 25...65 for AR 30
0378109 001 Assembly kit; DEF DN 80...100 for AR 30
0378110 001 Assembly kit; DEF DN 25...65 for A44
0378111 001 Assembly kit; DEF DN 80...125 for A 44
0378112 001 Assembly kit; DEF DN 150...200 for A44
0378113 001 Assembly kit; DEF DN 25...100 for ASF 122/123

1) at Δp 1.5 bar

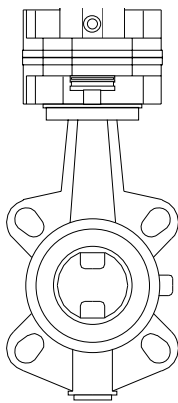

B06331

Combination with actuator with return spring

Drive ¹⁾			ASF 122 F120	ASF 123 F122	ASF 123S F122
Input			2-point	3-point	0...10 V
Running time			90 s	90 s	90 s
Spring return			15 s	15 s	15 s
Butterfly valve:	Δp_{\max}	Δp_s			
DEF 025 F200	10	10			
DEF 032 F200	10	10			
DEF 040 F200	10	10			
DEF 050 F200	10	10			
DEF 065 F200	7	7			
DEF 080 F200	4	4			
DEF 100 F200	2	2			

1) Assembly kit 0378113 001 required (weight 0.5 kg)

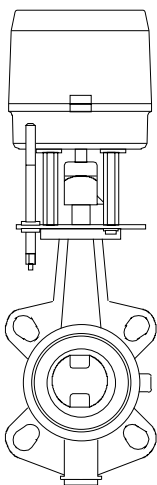

B01425a

Combination with electric motor drive AR30 W2.

Drive ¹⁾		AR30 W23	AR30 W23S
Input		3-point	0...10 V
Running time		120 s	120 s
Butterfly valve	Δp_{\max}		
DEF 025 F200	10		
DEF 032 F200	10		
DEF 040 F200	10		
DEF 050 F200	10		
DEF 065 F200	7		
DEF 080 F200	4		
DEF 100 F200	2		

1) For DN 25...65: Assembly kit 0378108 001 required (weight 0.4 kg)
For DN 80 and 100: Assembly kit 0378109 001 required (weight 0.4 kg)

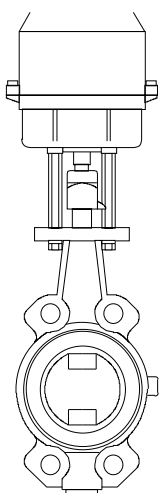

B01426

Combination with electric motor drive A44

Drive ¹⁾		A44 W2	A44 W2S
Input		3-point	0...10 V
Running time		120 s	120 s
Butterfly valve	Δp_{\max}		
DEF 025 F200	10		
DEF 032 F200	10		
DEF 040 F200	16		
DEF 050 F200	16		
DEF 065 F200	16		
DEF 080 F200	10		
DEF 100 F200	10		
DEF 125 F200	6		
DEF 150 F200	5		
DEF 200 F200	3		

1) For DN 25...65: Assembly kit 0378110 001 required (weight 0.2 kg)
For DN 80...125: Assembly kit 0378111 001 required (weight 0.2 kg)
For DN 150 and 200: Assembly kit 0378112 001 required (weight 0.2 kg)

Complete type designation: Butterfly valve and drive with corresponding F-version
Butterfly valve: F-version, technical data and accessories: see table of types on page 1
Drive: F-version, technical data and accessories: see section 51
Example: DEF 65 F200/ASF 123S F122

$\Delta p_{\max}[\text{bar}]$ = Maximum permitted pressure difference over the valve at which the drive can still reliably open and close the valve, taking account of Δp_v .
 $\Delta p_s [\text{bar}]$ = Maximum permitted pressure difference over the valve in case of a fault (pipe break downstream of the valve) at which the drive can close the valve reliably with 'fast' performance of the stroke.

Operation

Can be actuated by means of motor drive or actuator with spring-return action to attain any intermediate position. Can be used as a shut-off device in conjunction with actuator ASF 122 / 123. In this case, the butterfly is actuated such that it will move either to its closed or open position in the event of a power failure or whenever a limiter comes into operation.

Manual butterfly adjustment:

- AR30 by means of a hand crank (mounted in the adapter plate)
- A44 W by means of a hand crank (mounted under the hood)
- ASF 122 / 123 manually after the coupling has been released

Information for engineering and installation

The butterfly valve is installed by clamping and then screw-mounting the unit between two flanges. The butterfly must be opened to at least 10% during installation. A special lining of the housing eliminates the need for flange gaskets.

Flow admission is possible from either side.

Additional design information

Design length of the butterfly valve according to EN 558 series 20 from nominal diameter 40. Collar is lined such that no contact between cast iron medium is possible.

Drive flange acc. to EN ISO 5211 NFE 29-402

Flange accommodation according to DIN 2501

DN	Pressure Equipment Directive		CE
25	97 / 23 / EC	Art. 3.3	–
32	97 / 23 / EC	Art. 3.3	–
40	97 / 23 / EC	Art. 3.3	–
50	97 / 23 / EC	Art. 3.3	–
65	97 / 23 / EC	Cat. I	CE
80	97 / 23 / EC	Cat. I	CE
100	97 / 23 / EC	Cat. I	CE
125	97 / 23 / EC	Cat. I	CE
150	97 / 23 / EC	Cat. I	CE
200	97 / 23 / EC	Cat. I	CE

Dimension drawings 5M016

DEF 25...65

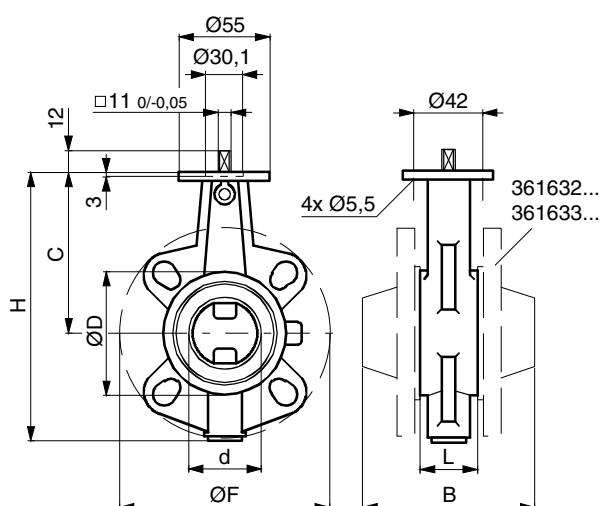

DN	d	C	H	L	ØD	B		ØF	
						PN6	PN10/16	PN6	PN10/16
25	32	104	149	33	64	103	109	100	115
32	32	104	154	33	69	103	113	120	140
40	40	113	178	33	82	109	117	130	150
50	50	126	209	43	95	119	133	140	165
65	62	134	226	46	115	122	136	160	185

M10016

DEF 80...200

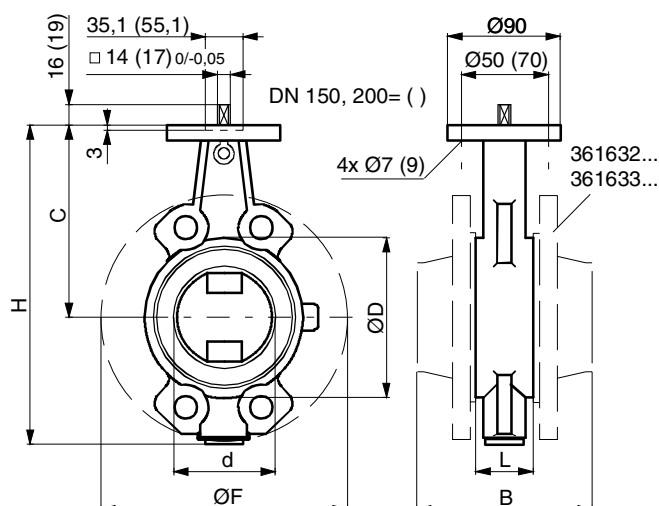

DN	d	C	H	L	ØD	B		ØF	
						PN6	PN10/16	PN6	PN10/16
80	78	157	260	46	138	130	146	190	200
100	98	167	281	52	158	142	156	210	220
125	123	180	306	56	188	152	166	240	250
150	147	203	355	56	212	152	166	265	285
200	197	228	403	60	250	170	182	320	340

M10017

with drive A44

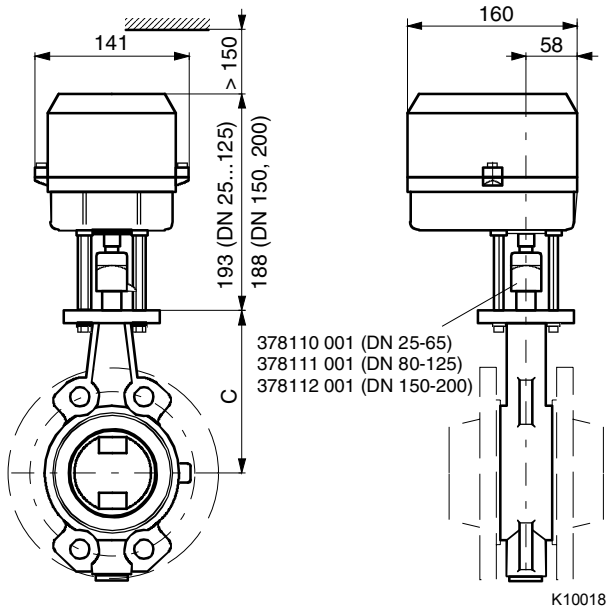

with drive AR30

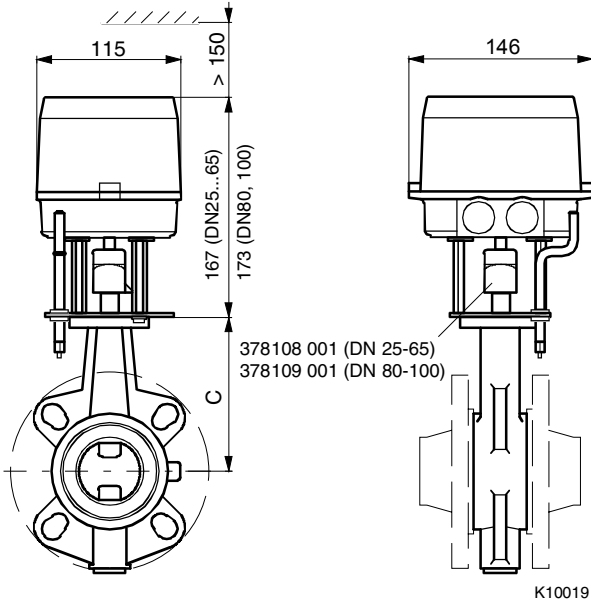

DN 25...100 with drive ASF 122, ASF 123

