

## VQE: 2-way flanged valve, PN 16

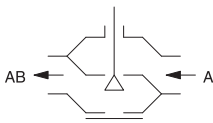

VQE



### Improving energy efficiency

Efficient use in continuous control systems

### Features

- Continuous control of cold/hot water and low-pressure steam up to 115 °C in closed circuits<sup>1</sup>
- Water quality as per VDI 2035
- In combination with valve actuators AVM 322(S), AVM 234S and AVF 234S as control unit
- Not suitable for drinking water or potentially explosive atmospheres
- Valve with flange connection as per EN 1092-2, seal form B
- Regulating valve, free of silicone grease, painted black
- Characteristic can be set with SUT (SAUTER Universal Technology) valve actuators to linear, equal-percentage or quadratic
- The valve is closed when the spindle is moved out
- Closes against the pressure
- Valve body and seat made of grey cast iron
- Stainless-steel spindle
- Plugs made of stainless steel with metal-to-metal seal
- Stuffing box made of stainless steel with wiper ring and double O-ring seal made of EPDM

### Technical data

Parameters	
Nominal pressure	PN 16
Connection	Flange as per EN 1092-2, form B
Valve characteristic	Equal-percentage
Control ratio of valve	> 30:1
Stuffing box	2 EPDM O-rings
Leakage rate	Class III as per DIN EN 60534-4 (0.001 x $k_{vs}$ )
Valve stroke	20 mm (DN 65...80) 40 mm (DN 100...150)
Ambient conditions	
Operating temperature <sup>2</sup>	-10...150 °C
Operating pressure	Up to 120 °C 16 bar At 150 °C 14.4 bar Between 120 °C and 150 °C, a linear interpolation can be performed
Standards and directives	
Pressure and temperature data	EN 764, EN 1333
Flow parameters	EN 60534 (page 3)
Pressure equipment directive	97/23/EC (fluid group II) With CE label

### Overview of types

Type	Nominal diameter	$k_{vs}$ value	Weight
VQE065F300	DN 65	63 m <sup>3</sup> /h	23.8 kg
VQE080F300	DN 80	100 m <sup>3</sup> /h	30.2 kg
VQE100F300	DN 100	160 m <sup>3</sup> /h	41.3 kg
VQE125F300	DN 125	220 m <sup>3</sup> /h	62 kg
VQE150F300	DN 150	320 m <sup>3</sup> /h	89 kg



<sup>1</sup> Air humidity must not exceed 75%

<sup>2</sup> At temperatures below 0 °C, use a stuffing box heater. Use adaptor (accessory) at temperatures above 130 °C

**Accessories**

Type	Description
0372336180	Adaptor (required when temperature of the medium is 130...150 °C) from DN 65
0378284100	Stuffing box heater 230V~, 15 W for medium below 0 °C
0378284102	Stuffing box heater 24V~, 15 W for medium below 0 °C
0378369101	Complete replacement stuffing box for DN 65...100

**Combination of VQE with electric actuators**

**i** Warranty: The technical data and pressure differences indicated here are applicable only in combination with SAUTER valve actuators. The warranty does not apply if used with valve actuators from other manufacturers.

**i** Definition of  $\Delta p_s$ : Maximum admissible pressure drop in the event of a malfunction (pipe break after the valve) at which the actuator reliably closes the valve by means of a return spring.

**i** Definition of  $\Delta p_{max}$ : Maximum admissible pressure drop in control mode at which the actuator reliably opens and closes the valve.

**Combination of VQE with electric actuators, actuating power 1000 N**

Actuator	AVM322F120 AVM322F122	AVM322SF132
Actuating power	1000 N	1000 N
Control signal	3-point	0...10 V
Running time	120/240 s	120/80 s
$\Delta p$ [bar]		
Closes against the pressure	$\Delta p_{max}$	$\Delta p_{max}$
VQE065F300	2.5	2.5
VQE080F300	1.5	1.5
Cannot be used to close with the pressure		

**i** Maximum media temperature: 100 °C

**Combination of VQE with electric actuators, actuating power 2500 N, 2000 N**

Actuator	AVM234SF132	AVF234SF132 AVF234SF232	
Actuating power	2500 N	2000 N	
Control signal	2-/3-pt., 0...10 V, 4...20 mA	2-/3-pt., 0...10 V, 4...20 mA	
Running time DN 65, DN 80	40/80/120 s	40/80/120 s	
Running time DN 100...150	80/160/240 s	80/160/240 s	
$\Delta p$ [bar]			
Closes against the pressure	$\Delta p_{max}$	$\Delta p_{max}$	$\Delta p_s$
VQE065F300	3.0	3.0	5.1
VQE080F300	3.0	3.0	3.4
VQE100F300	2.0	2.0	2.2
VQE125F300	1.5	1.4	1.4
VQE150F300	1.0	1.0	1.1
Cannot be used to close with the pressure			

**i** Spring return: AVF234SF132 normally closed (NC); AVF234SF232 normally open (NO)

**i** At temperatures above 130 °C, accessories are required

## Description of operation

The valve can be moved to any intermediate position with an electric actuator. When the spindle is moved out, the control passage of the valve is closed. The nominal diameters DN 65 to DN 150 may only be used when employing the “against the pressure” closing procedure. The flow direction marked on the valve must be observed. The flow parameters correspond to EN 60534.

## Closing against the pressure

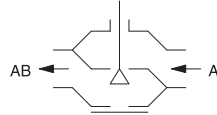

These control valves are characterised by their reliability and precision and make an important contribution towards environmentally friendly regulation. They meet difficult challenges such as the quick-closing function, overcoming differential pressures and controlling medium temperatures, all with a low noise level.

The valve spindle is automatically and firmly connected to the actuator spindle. The stainless steel plug controls the equal-percentage flow rate in the control passage. The tightness of the valve is ensured by the seat incorporated in the body.

The stuffing box is maintenance-free. This consists of a stainless steel body, two O-rings, a wiper ring and a grease reserve. This is free of silicone grease, and silicone oil may not be used for the spindle.

## Intended use

This product is only suitable for the purpose intended by the manufacturer, as described in the “Description of function” section.

All related product documents must also be adhered to. Changing or converting the product is not admissible.

## Notes on engineering and installation

The valves are combined with the valve actuators without a spring return or with valve actuators with a spring return. The actuator is mounted directly on the valve and fastened with screws. The actuator is connected with the valve spindle automatically. When the system is commissioned, the actuator moves out and the connector closes automatically when it reaches the lower valve seat. The stroke of the valve is also detected by the actuator, and no further adjustments are required. Therefore the force on the seat is always the same and the smallest amount of leakage is ensured. With the SUT actuators, the characteristic can be set to linear or quadratic as required.

## Additional technical data

Technical information	
SAUTER slide rule for valve sizing	7 090011 001
Manual on slide rule	7 000129 001
Technical manual on control units	7 000477 001
Parameters, fitting notes, control, general information	Applicable EN, DIN, AD, TRD and UVV regulations
Fitting instructions	P100013463
AVM 234S assembly	MV 505919
AVF 234S assembly	MV 505920
AVM 322(S) assembly	P100011900
Declaration on materials and the environment	MD 56.117

## Fitting position

The final control element can be fitted in any position, but the hanging position is not recommended. Condensate, drops of water, etc. must be prevented from entering the actuator. When installed horizontally, and with regard to the valve spindle, the admissible actuator or support weight, without structural support, is max. 25 kg.

When the actuator is mounted on the valve, make sure the plug is not twisted on the seat (this can damage the sealing surface). When insulating the valve, it may only be insulated up to the connecting clip of the actuator.

To increase the functional reliability of the valves, the system should conform to DIN/EN 14336 (heating systems in buildings). DIN/EN 14336 states, amongst other things, that the system has to be flushed through before being put into service.

### Using with steam

The valves can be used for low-pressure steam up to 115 °C with the same  $\Delta p_{\max}$  values. When using the valve, make sure that it does not operate mainly on the lower third of its stroke range. This leads to an extremely high flow speed, which greatly reduces the serviceable life of the valve.

### Using with water

So that impurities are retained in the water (welding beads, rust particles, etc.) and the spindle seal is not damaged, we recommend installing collecting filters, for example one for each floor or pipe run. Water requirements according to VDI 2035. When using an additive in the water, the compatibility of the materials must be checked with the manufacturer of the medium. The materials table shown below may be used. When glycol is used, we recommend using a concentration of between 20% and 55%.

### Other information regarding hydraulics and noise in systems

The valves can be used in a low-noise environment. To prevent noise, the pressure differences  $\Delta p_{\max}$  listed below should not be exceeded.

The pressure difference  $\Delta p_v$  is the maximum pressure that may act on the valve regardless of the stroke position, in order that the risk of cavitation and erosion is limited. These values are irrespective of the actuator force. Cavitation accelerates wear and causes noises. To prevent cavitation, the pressure differential on the valve should not exceed the value  $\Delta p_{\text{krit}}$ :

$$\Delta p_{\text{krit}} = (p_1 - p_v) \times 0.5$$

$p_1$  = upstream pressure before the valve (bar)

$p_v$  = steam pressure at operating temperature (bar)

The calculation works with absolute pressure.

For the spring return, the stated  $\Delta p_s$  values are also the permissible differential pressure up to which the actuator can guarantee that the valve is closed in the event of an incident. Because this is a quick-closing function with a "fast" stroke movement (using a spring), this value can exceed  $\Delta p_{\max}$ .

**Flow-rate chart**

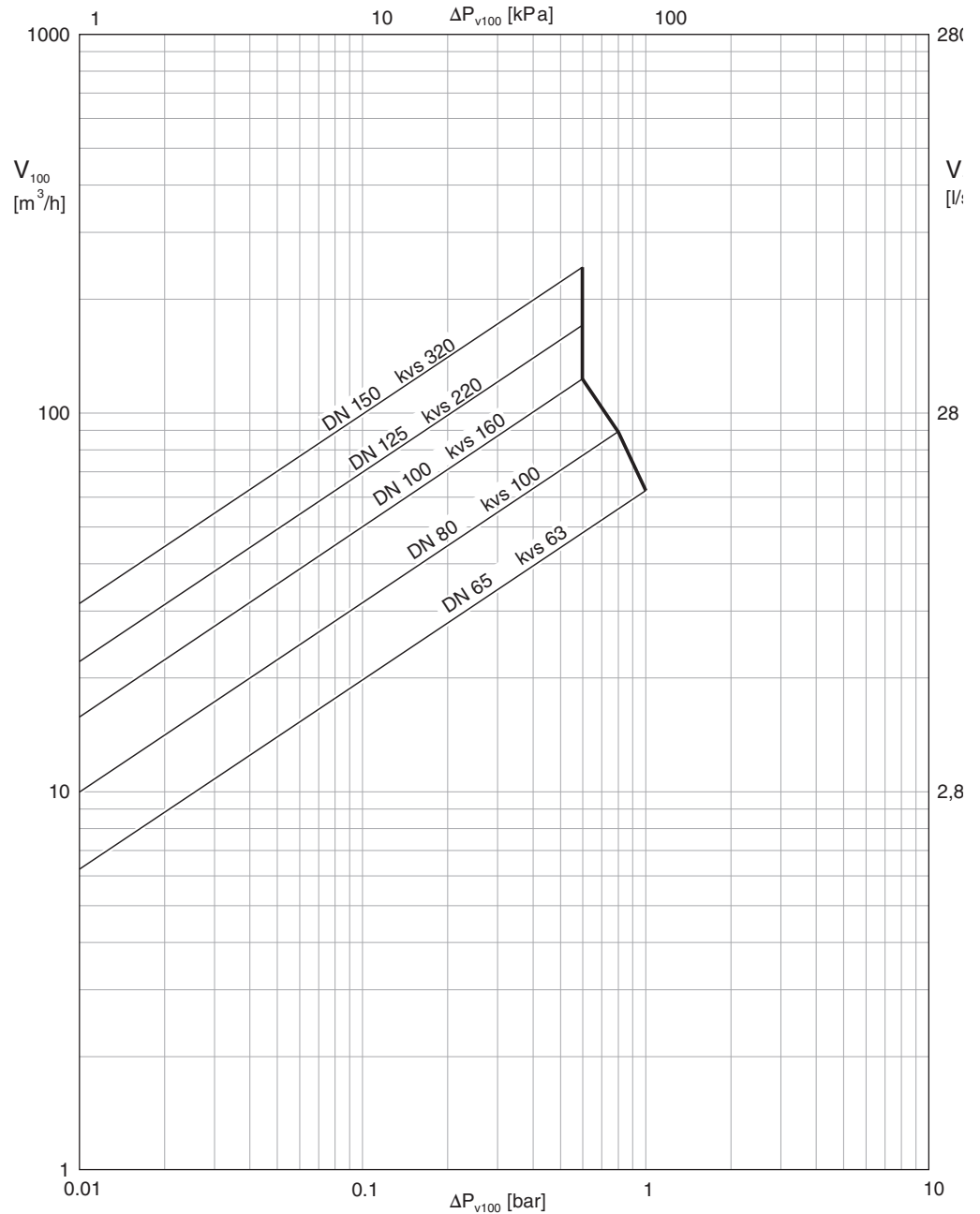

Type	$\Delta p_v$	
	Against the pressure	With the pressure
VQE065F300	1.0	-
VQE080F300	0.8	-
VQE100F300	0.6	-
VQE125F300	0.6	-
VQE150F300	0.6	-

**Additional version information**

Valve body made of grey cast iron as per EN 1561, code EN-GJL-250, material number EN-JL 1040 with smooth drilled flanges as per EN 1092-2, seal form B.

Valve body protected by matt paint RAL 9005 jet black.

Fitted in the piping with welding flange as per EN 1092-1.

Valve fitting length as per EN 558-1, basic series 1.

Flat seal on valve body made of asbestos-free material.

### Material numbers according to DIN

	DIN materials	DIN code
Valve body	EN-JL 1040	EN-GJL-250 (GG25)
Valve seat	EN-JL 1040	EN-GJL-250
Spindle	1.4021	X20Cr13
Plug	1.4021	X20Cr13
Stuffing box	1.4104	X12CrMoS-17

### Additional details on the definitions of pressure difference

#### $\Delta p_v$ :

Maximum admissible pressure difference over the valve at every stroke position, limited by noise level and erosion.

With this parameter, the valve is characterised as a flow element with specific hydraulic behaviour. Monitoring the cavitation and erosion along with the associated noise increases the service life and the operational capacity.

#### $\Delta p_{max}$ :

Maximum admissible pressure difference over the valve at which the actuator can reliably open and close the valve.

The following are considered: Static pressure and flow effects. This value ensures trouble-free stroke movement and closing of the valve. The value  $\Delta p_v$  of the valve is never exceeded.

#### $\Delta p_s$ :

Maximum admissible pressure difference over the valve in the event of a malfunction (e.g. power failure, excessive temperature or pressure, pipe break) at which the actuator can close the valve tightly and, if necessary, maintain the full operating pressure against atmospheric pressure. Because this is a safety function with a rapid stroke movement,  $\Delta p_s$  can be greater than  $\Delta p_{max}$  or  $\Delta p_v$ . The disruptive flow effects that arise here are quickly passed through and are of minor importance in this mode of operation.

For 3-way valves, the values only apply to the control passage.

#### $\Delta p_{stat}$ :

Line pressure behind the valve. This essentially corresponds to the idle pressure when the pump is switched off, caused for example by the fluid level in the system, increased pressure due to pressure tanks, steam pressure, etc.

For valves that close with pressure, the static pressure plus the pump pressure are used.

### Disposal

When disposing of the product, observe the currently applicable local laws.

More information on materials can be found in the Declaration on materials and the environment for this product.

### Characteristic for actuators with positioner

On actuator AVM 322S, AVM 234S or AVF 234S

Equal-percentage/linear/quadratic

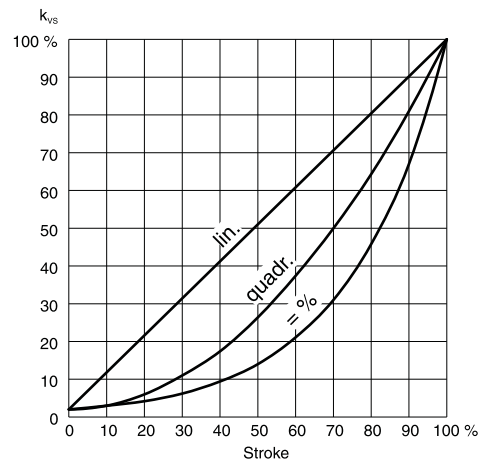

Dimension drawings

DN 65...150

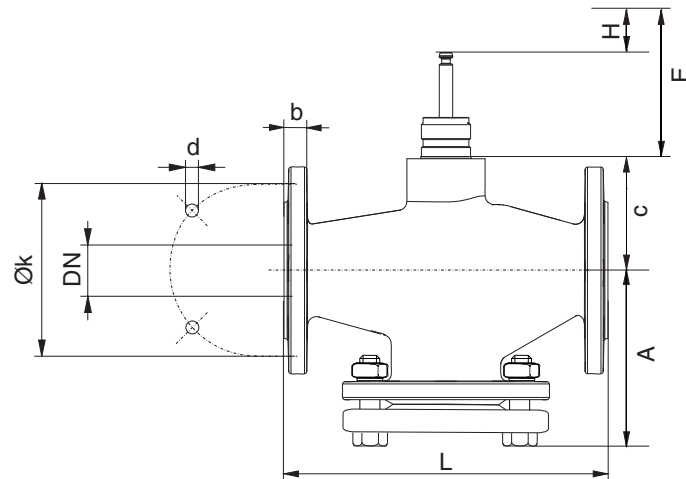

VQE	DN	A	c	L	H	k	d	b	E
065	65	149.5	102	290	20	145	4x19	20	93
080	80	161.5	112	310	20	160	8x19	22	93
100	100	181.5	127	350	40	180	8x19	24	113
125	125	233.5	160	400	40	210	8x19	27	113
150	150	246.5	181	480	40	240	8x23	27	113

Combinations

AVM 234

AVF 234

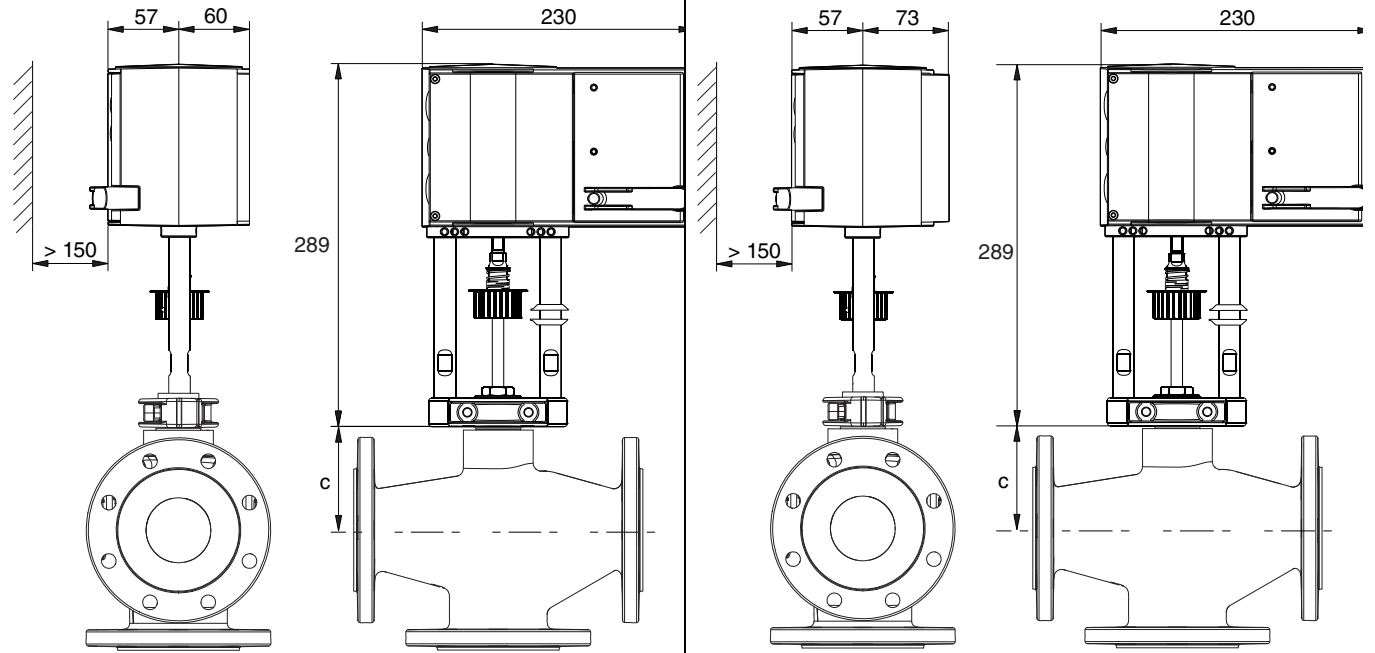

**AVM 322(S)**

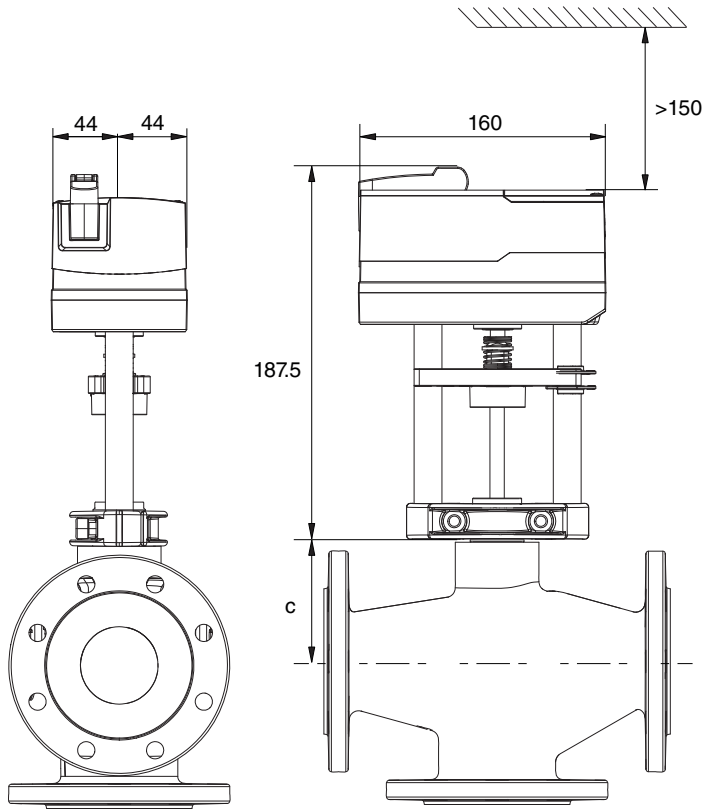

**Accessories**

